

Operation and Maintenance Manual



Contents

1. Quality Assurance Policy Statement
2. Care and Protection
3. Cut-out Details for VS & VSO Vision Panels
4. Bead Details and Cross Section Drawings
5. COSHH Data Sheet
6. Lifetime Warranty Certificate

Quality Assurance Policy Statement



Vistamatic Limited aims to provide defect-free products and services to our customers, on time and within budget.

The Company operates a quality management system which has gained BS ISO 9001:2015 Certification, including aspects specific to the Glass & Glazing Industry.

The quality management system is described and detailed in the Procedure Manual. All Vistamatic personnel understand the importance of quality and abide with the contents of the manual.

Vistamatic Limited complies with all legislation relevant to the Glass & Glazing Industry and also the Health and Safety at Work Act 1974.

The Company constantly monitors its quality performance and will implement improvements when appropriate.

Care and Protection of your Vistamatic Vision Panels

By following a few simple rules during usage and cleaning you can prolong the life of your Vistamatic Vision Panels and assist in retaining their good appearance.

DO's

Clean only with mild soaps or detergents added to water, or a proprietary non abrasive glass cleaner.

Clean using a soft or synthetic window leather.

Use a squeegee or soft cloth for drying the window.

DO NOT's

Use brushes or sharp edge items at any time on the Vistamatic Vision Panels.

If in doubt please contact Vistamatic Ltd about further guidance in respect of cleaning.

Vistamatic is BS EN ISO 9001:2015 registered company.

Isometric CAD drawings

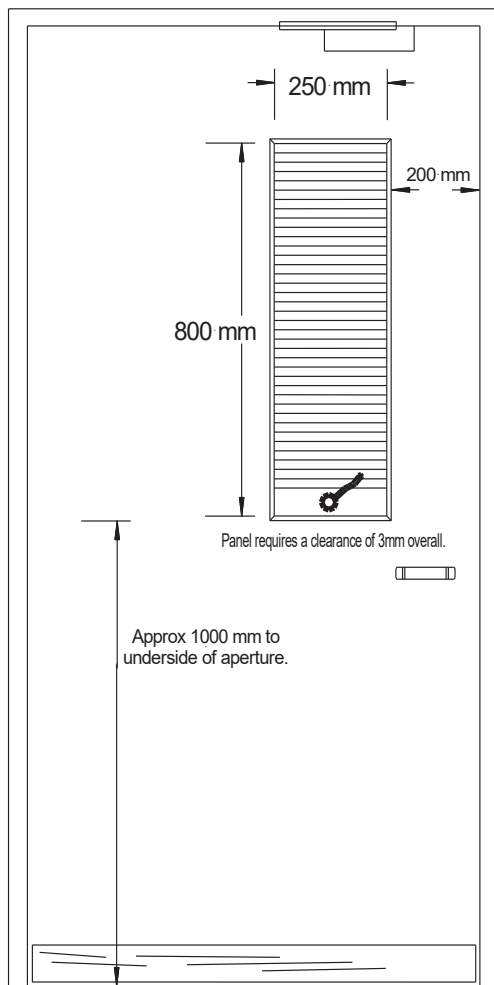

All sizes shown are approximate and intended as a guide only.

Drawing is not to scale.

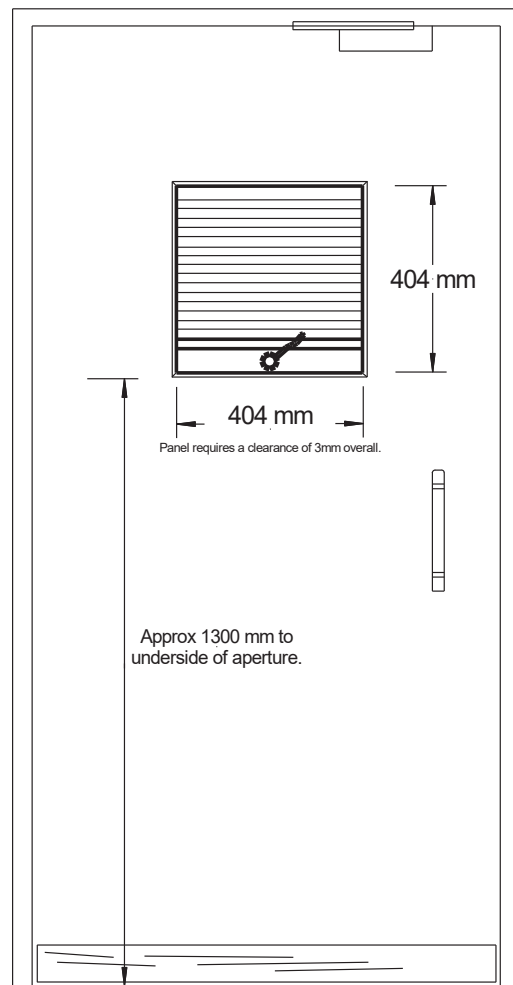

All sizes shown are approximate and intended as a guide only.

Drawing is not to scale.

Isometric CAD drawings

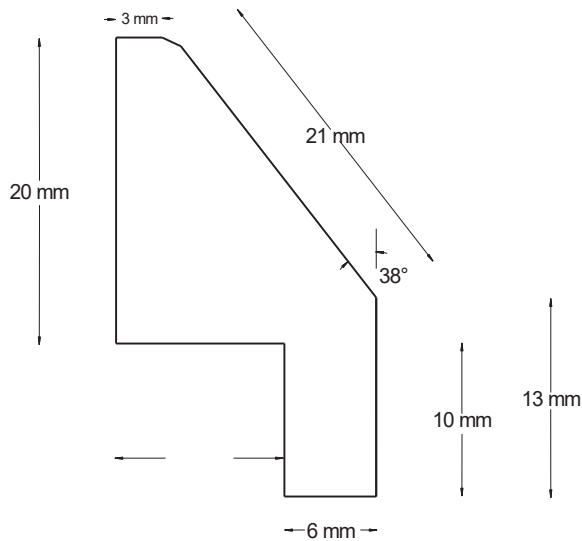

Non Fire Rate Bead Details

Non Fire Rate Bead Details
Cross Section Vistamatic Max Panel

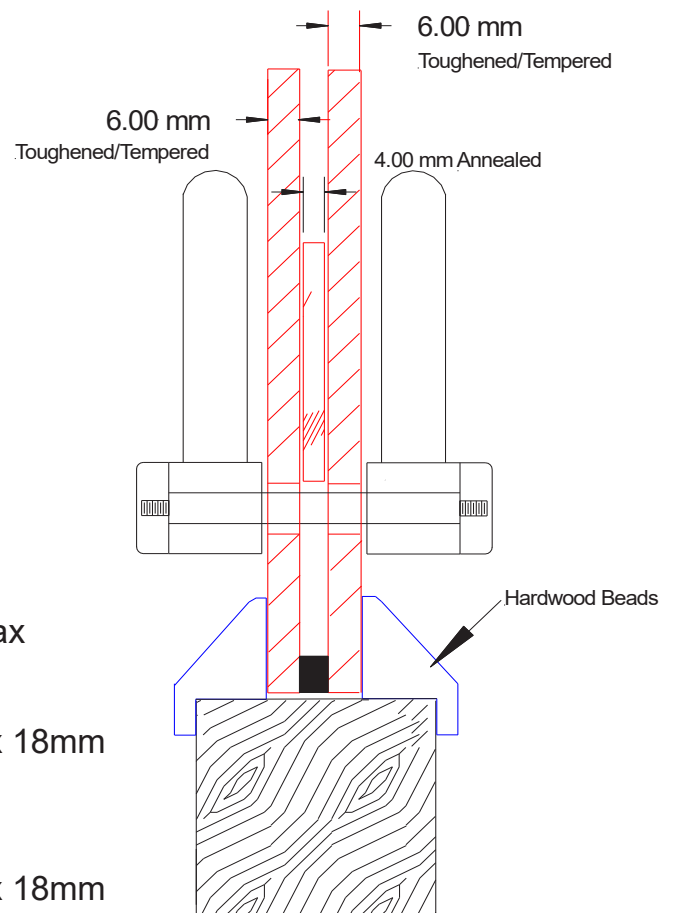

Vistamatic Max
Panel Size

404mm x 404mm x 18mm

And

250mm x 800mm x 18mm

For FD30 and FD60 glazing information and drawings please refer to our fire certification available to download from our website.

COSHH Data Sheet



Non Fire Rated Vistamatic Vision Panels

Basic non fire rated Vistamatic Vision Panel comprises of:
6mm Toughened Glass / 4mm Annealed Glass / 6mm Toughened Glass.

The outer panes could be substituted for any of the following glasses in any combination. 8mm/10mm/12mm/15mm or 19mm Toughened Glasses or any combination of Laminated or Acoustic Glasses.

FD30 Fire Rated Vistamatic Vision Panels

Basic FD30 fire rated Vistamatic Vision Panel comprises of :
6mm Toughened Glass / 4mm Annealed Glass / 10mm Pyro EX30 Toughened Glass

The outer Pyro EX30 outer pane can be substituted for any of the following glasses in any combination:
10mm/12mm/15mm or 19mm Pyro EX30 Toughened Fire Glass or any combination of Laminated FD30 Fire Glasses.

See previous sheet for intumescent details.

FD60 Fire Rated Vistamatic Vision Panels

Basic FD60 fire rated Vistamatic Vision Panel comprises of :
6mm Toughened Glass / 4mm Annealed Glass / 19mm Pyro Ex Rated Glass.

See previous sheet for intumescent details.



Warranty Certificate

SITE NAME:

SITE ADDRESS:

DATE:

Thank you for purchasing your
Vistamatic® Vision Panels.

Signed on behalf of Vistamatic Limited



Managing Director

Below are the terms under which your Vistamatic® Vision Panels are covered under our manufacturer's warranty.

Terms and Conditions

- The warranty applies to the user of the product and is not transferable.
- The warranty applies to an original installation and does not cover previously installed products.
- The warranty applies only to manufacturing or material defects and does not apply to normal wear and tear, inappropriate use or accidental damage.
- The warranty applies only if products have been installed according to our instructions and maintained according to our recommendations.
- The warranty applies only to the product itself.
- The warranty is only valid for products installed in the U.K and Ireland.
- If a product is found to be of faulty manufacture VISTAMATIC® reserve the right to either replace or repair the product and excludes any claim for consequential loss or damage.
- Should you have a claim against this guarantee you should contact VISTAMATIC® warranty department within 21 days of the fault occurring.
- VISTAMATIC® reserves the right to charge for engineer's time and replacement parts if a claim is not due to faulty manufacture or components.
- No claim will be accepted if a product is installed with a fault that would have been clearly visible before installation. The warranty does not cover equipment which has been damaged due to misuse, abuse, or accident.

*Lifetime Warranty against faulty manufacture:

If a defect in materials or workmanship appears in your VISTAMATIC® glazed secure vision panel, Vistamatic Limited will provide, at your choice, either free replacement or repair of your product within 28 working days of the reported fault and return of faulty panel. All and any carriage or freight charges at the registered owners cost.

Care and Protection of your VISTAMATIC® glazed secure vision panels.

By following a few simple rules during usage and cleaning you can prolong the life of your Vistamatic® vision panels and assist in retaining their good appearance.

DO: Clean only with mild soaps or detergents added to water or a proprietary non abrasive glass cleaner. Clean using soft or synthetic window leather. Use a squeegee or soft cloth for drying the window.

DO NOT: Use brushes or sharp edge items at any time on Vistamatic® vision panels. Do not attempt to use any type of lubricant on operating mechanism. If in doubt please contact Vistamatic Ltd.

Vistamatic® is a BS EN ISO 9001: 2008 Registered Firm.

*Any alteration to original specification will negate the Warranty.